

Applications:

EBM series hinged cover disconnect switches are used:

- To disconnect motor, lighting and other circuits.
- In locations made hazardous by the presence of flammable gases or vapors or ignitable dusts.
- Indoors or outdoors in damp, wet and dirty locations, or in areas where frequent washdowns, heavy rain or water spray is prevalent.
- To provide disconnect means and short circuit protection (fusible version).
- On switchracks or other assemblies where it is desired that motor control be centrally located.

Features:

- Rugged corrosion resistant cast copper-free aluminum construction (less than 0.4 of 1%).
- Switch operating handle is located through the right side wall of the body, permits visual confirmation of correct alignment and operation.
- Total compliance to the wiring end room requirements of the National Electrical Code.
- Semi-clamshell enclosure design, with an external flanged ground joint between body and cover makes interior components more accessible.
- Minimum enclosure-to-enclosure spacing with little interference between the opened cover and an adjacent enclosure.
- Stainless steel hinges allow the cover to swing well out of the way.
- Stainless steel quick release captive hexhead cover bolts. Stainless steel springs provide clear indication that cover bolts are fully retracted from the body.
- Switch operating handle can be padlocked in either the "ON" or "OFF" position.
- Neoprene cover gasket permanently attached to the cover seals out moisture.
- Bodies have top and bottom drilled and tapped conduit entrances for power and conduits. Removable reducers are supplied as standard, to accommodate smaller size conduits. All conduit entrances are plugged.
- Tap on mounting feet.

Certifications and Compliances:

- NEC/CEC:
 - Class I, Division 1 & 2, Groups B, C, D
 - Class II, Division 1, Groups E, F, G
 - Class II, Division 2, Groups F, G
 - Class III
- UL Standards: UL1203
- High A.I.C. Rating (Interrupting Capacity)
 - For Class I, Div. 1, Groups C & D only

| Volt | RMS Symm-Amperes |
|------|------------------|
| 240 | 65,000 |
| 480 | 50,000 |
| 600 | 25,000 |

- CSA Standard: C22.2 No. 30
- NEMA: 3, 3R, 4 \ddagger , 7BCD, 9EFG, 12

Standard Materials:

- Body and cover – copper-free aluminum
- Operating handle – copper-free aluminum
- Operating shaft and bushing – stainless steel
- Interior parts – sheet steel, electrogalvanized
- Cover bolts, washers and retractile springs – stainless steel
- Hinges – stainless steel

Electrical Rating Ranges:

- 600 VAC
- 30, 60 and 100 Amp

| Amp Rating | Max. HP Rating | | | DC using 2 poles only 250V Max. | Enclosure | |
|--------------------|----------------|----|----|------------------------------------|------------------------------|--------------------------|
| | AC Polyphase | | | | With Switch 600VAC Cat. # | Without Switch Cat. # |
| Non-Fusible | | | | | | |
| 30 | 10 | 20 | 25 | 7½ | EBMBB FD W30360 | EBMBB FD |
| 60 | 20 | 40 | 60 | 15 | EBMBB FD W60360 | EBMBB FD |
| 100 | 30 | 75 | 75 | 25 | EBMBD FD W10360 | EBMBD FD |
| Fusible | | | | | | |
| 30 | — | 5 | 7½ | 5 | EBMBB FD W30361 | EBMBB FD |
| 60 | — | 15 | 15 | 10 | EBMBB FD W60361 | EBMBB FD |
| 100 | 15 | 25 | 30 | 20 | EBMBD FD W10361 | EBMBD FD |

Options:

- For available options, see pages 478–479.



Ordering Information:

To order an enclosure complete with the disconnect switch, select the catalog number (based on the necessary rating of the switch), from the listing below.

Enclosures only, without the disconnect switch, can be ordered. Select the catalog number for the required enclosure from the listing below.

‡ Enclosure not suitable for NEMA 4 with cover mounted operators.

EBM Disconnect Switches and Enclosures

600 VAC Heavy Duty

Cl. I, Div. 1 & 2, Groups B, C, D
 Cl. II, Div. 1, Groups E, F, G
 Cl. II, Div. 2, Groups F, G
 Cl. III
 NEMA 3, 3R, 4‡, 7BCD, 9EFG, 12

Explosionproof
 Dust-Ignitionproof
 Watertight
 Wet Locations

2A

Dimensions In Inches:

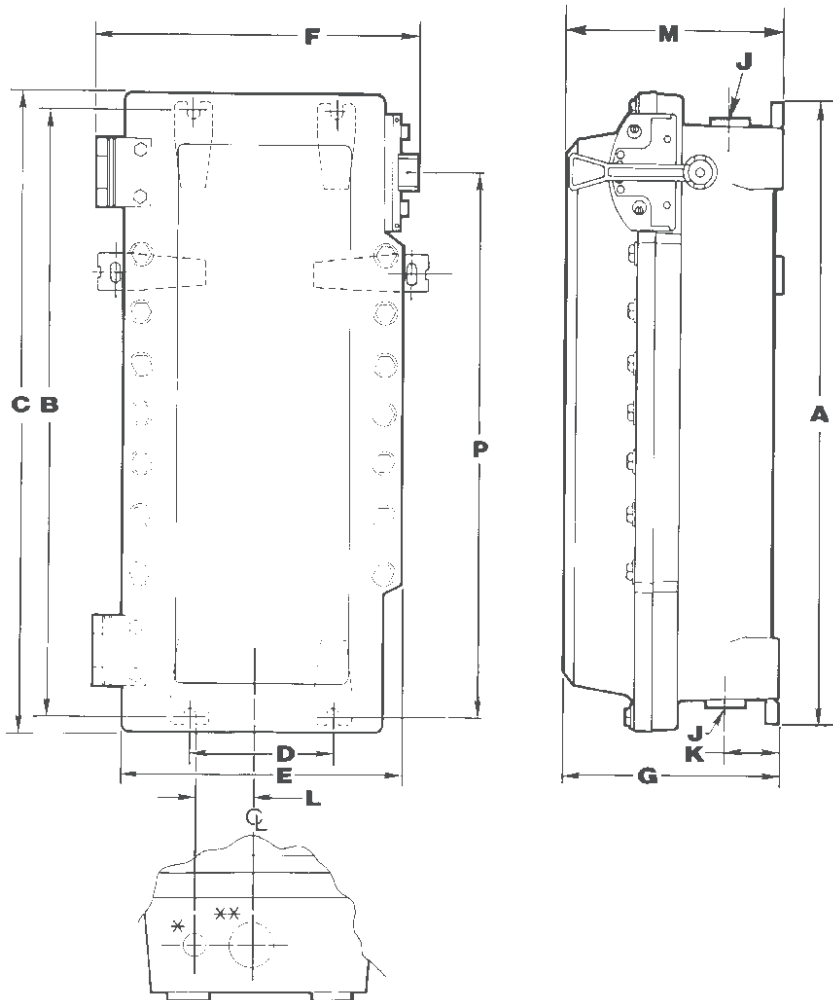

Dimensions are approximate, not for construction purposes.

*1" D & T conduit entry for control conductors supplied with PLG plug top and bottom.

**Conduit entrance(s) for power conductors (top and bottom). (All conduit entrance(s) supplied with RE reducer and PLG plug.)

| Enclosure Only Cat. # | Enclosure Size Symbol | **J Conduit Entry Trade Size | | | | | | | | | | | | | |
|-----------------------|-----------------------|------------------------------|-------|-------|-------|------|-------|-------|-------|------|------|------|------|-------|-------|
| | | A | B | C | D | E | F | G | D&T† | w/RE | K | L | M | P | |
| 30 and 60 Amp Frame | EBMBB | B | 25.75 | 24.75 | 26.90 | 6.00 | 13.03 | 14.46 | 10.25 | 2" | 1.5" | 3.25 | 3.13 | 10.25 | 22.00 |
| 100 Amp Frame | EBMBD | D | 28.25 | 27.25 | 29.40 | 6.00 | 13.03 | 14.46 | 10.25 | 3" | 2.5" | 3.25 | 3.13 | 10.25 | 24.50 |

‡ Enclosure not suitable for NEMA 4 with cover mounted operators.

† Drilled & Tapped.

2A