



## Champ VMVL LED with emergency back-up battery

Lighting and back-up power is critical to any safety plan. That's why we've expanded our offering to include the Champ VMVL EM LED luminaire with an integrated battery backup.

In the event of power loss or power interruption, Champ® VMVL LED with built-in back-up power provides 90 minutes of emergency lighting to help keep your people safe and your plant running smoothly.

Designed for maintenance-free illumination in egress and emergency lighting areas, the Champ VMVL is rated for indoor and outdoor emergency lighting in hazardous locations, such as manufacturing plants, heavy industrial, chemical, petrochemical facilities, platforms, loading docks and parking areas.



### Certifications and compliances:

#### NEC & CEC

- Class I, Division 2, Groups A, B, C, D
- Class II, Division 1, Groups E, F, G
- Class III
- Class I, Zone 2
- Simultaneous Presence
- Wet Locations, Type 4X, IP66

#### UL standards

- UL 844 Hazardous (Classified)
- UL1598 Luminaires, UL1598A Marine
- UL924 (Emergency Luminaire)

#### CSA standard

- CSA C22.2 No. 137

### Electrical ratings:

**Current draw: 120-277 VAC**

Model	Input power (watts)	Nominal lumens	Battery EM not charging	Battery EM charging*
<b>VMVL-3</b>	30	3,250	0.10 - 0.27A	0.12 - 0.32A
<b>VMVL-5</b>	46	5,537	0.16 - 0.45A	0.18 - 0.50A
<b>VMVL-7</b>	68	7,442	0.21 - 0.61A	0.23 - 0.66A
<b>VMVL-9</b>	76	9,234	0.26 - 0.76A	0.28 - 0.81A
<b>VMVL-11</b>	102	11,114	0.32 - 0.92A	0.32 - 0.92A

\*Maximum AC power draw by the charge controller is 4 Watts

All models - emergency output mode		All models	
<b>VMVL-UNV1</b>	1,000 lumens (100-277V)	<b>Surge protection</b>	4kV
<b>Voltage range, VAC*</b>	100-277V at 50/60 Hz	<b>Effective projected area</b>	1.35 ft <sup>2</sup>
<b>Power factor</b>	≥0.90	<b>Dimensions (HxW)</b>	15.68" x 11.56"
<b>THD</b>	≤20%	<b>Weight</b>	32.7 lbs

### Temperature codes:

	VMVL-3 to 7		VMVL-9 & 11
	40°C	50°C	40°C
<b>Class I, Division 2</b>	T4A	T4A	T6
<b>Class II, Division 1</b>	T6	T6	T6
<b>Simultaneous rating Class I, Division 1 &amp; II</b>	T3A	T3	T3A
<b>Class I, Zone 2</b>	T4	T4	T6
<b>Zone 21</b>	68°C	68°C	68°C



Powering Business Worldwide

# Ordering information

Part number example: **VMVL-3-W-2A-G-UNV1-EM1**

Champ VMVL, 3,000 lumens, 4000K warm white, ¾" pendant mount, Type V optics, wire guard, 100-277 VAC driver, emergency driver system, clear glass lens

## VMVL - 3 - W - 2A - G - UNV1 - EM1 -

### Light source/intensity

<b>3</b>	3,000 nominal lumens
<b>5</b>	5,000 nominal lumens
<b>7</b>	7,000 nominal lumens
<b>9</b>	9,000 nominal lumens
<b>11</b>	11,000 nominal lumens

### Color temperature

<b>BLANK</b>	5000K, 70 CRI ( <i>cool white</i> )
<b>N*</b>	4000K, 80 CRI ( <i>neutral white</i> )
<b>W</b>	3000K, 80 CRI ( <i>warm white</i> )

\*Consult factory for lead time

### Lens guard

<b>BLANK</b>	No guard
<b>G</b>	Wire guard

### Optics

<b>BLANK</b>	Type V optic standard
<b>R1*</b>	Type I optic
<b>R3*</b>	Type III optic

\*Available on VMVL3 to VMVL7 models only.

### Voltage

<b>UNV1</b>	100-277 VAC, 50/60 Hz
-------------	-----------------------

### Options

<b>EM1</b>	Emergency driver system
<b>S812</b>	Trunion mount with pin
<b>S831</b>	Safety cable
<b>S890</b>	Quick clip

### Lens material

<b>BLANK</b>	Clear glass
<b>S891</b>	Diffused glass
<b>S903</b>	Polycarbonate

### Mounting

<b>BLANK</b>	No mounting module	<b>25A</b>	25mm pendant	<b>20C</b>	20mm ceiling
<b>J</b>	1-½" stanchion, 25° angled	<b>2B</b>	¾" cone pendant	<b>25C</b>	25mm ceiling
<b>P</b>	1-½" stanchion, straight	<b>3B</b>	1" cone pendant	<b>2TW</b>	¾" wall
<b>2A</b>	¾" pendant	<b>2HA</b>	¾" flexible pendant	<b>3TW</b>	1" wall
<b>3A</b>	1" pendant	<b>2C</b>	¾" ceiling	<b>20TW</b>	20mm wall
<b>20A</b>	20mm pendant	<b>3C</b>	1" ceiling	<b>25TW</b>	25mm wall

## Accessories (ordered separately)

### Accessories

<b>VMVL S812 K1*</b>	Trunion mount kit with pin
<b>VMVL S831 K1</b>	Safety cable
<b>VMVL S890 K1</b>	Quick clip
<b>P3002</b>	Wire guard

\*Available with ceiling mounted modules only.

### Replacement driver and battery kits

<b>VMVL EM BATTERY REPLACEMENT KIT</b>	Replacement EM battery
<b>VMVL EM DRIVER REPLACEMENT KIT</b>	Replacement EM driver

### Dimensions:

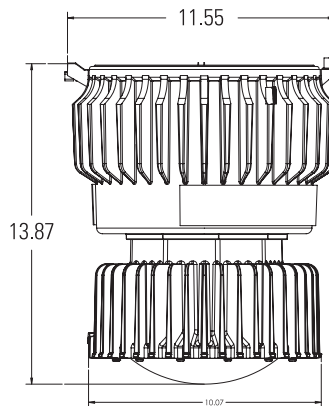

[Eaton.com/Champ](https://www.eaton.com/Champ)