

Champ Pro PFMA LED floodlights

3,000 to 7,000 lumens

UL Listed
CSA Certified
Marine & Wet Locations
Type 4X; IP66

5L

Applications:

- For general area illumination of locations with mounting heights from 9-15 feet
- Locations requiring continuous and consistent light levels in extreme ambient temperatures
- Extremely corrosive, wet, dusty, hot and/or cold conditions
- IP66, Type 4X, marine, wet locations and hose down environments
- Manufacturing plants; heavy industrial, chemical, food and beverage facilities; mining; platforms; loading docks; tunnels; outdoor wall and pole mounted areas

Certifications and compliances:

NEC/CEC:

- Marine and wet locations, Type 4X, IP66
- ABS

UL standards:

- UL1598
- UL1598A
- UL50E

CSA standard:

- C22.2 No. 250

FCC part 15/ICES-005 ver. 5:

- CAN ICES-005 (A)/NMB-005 (A)

Standard materials:

- Lamp housing and adapter – die cast aluminum with Corro-free epoxy powder coat
- Lens – heat- and impact-resistant glass (standard); diffused glass, clear polycarbonate, diffused polycarbonate (optional)
- Gaskets – silicone
- External hardware – stainless steel
- Factory sealed, no external seals required



LED system:

- High intensity discrete power emitters
- Cool white (5000K, 70 CRI) standard; warm white (3000K, 80 CRI) or neutral white (4000K, 70 CRI) (optional)
- NEMA 6x6 optical pattern
- Dimmable driver 0-10V

Photometrics:

- Refer to www.eaton.com (under the Resources tab of each product family) for specific photometric IES files

Electrical ratings:

Model	Weight lbs. (kg.)	Nominal lumens	Efficacy	Wattage	Voltage	Amps	Power factor	THD	Surge protection
PFMA-3-UNV1	14.70 (6.67)	3,400	111 lm/W	30.7	120-277 VAC, 50/60 Hz; 125-250 VDC	0.26	0.90	≤ 20%	6kV
PFMA-5-UNV1	14.70 (6.67)	5,200	116 lm/W	44.9	120-277 VAC, 50/60 Hz; 125-250 VDC	0.37	0.90	≤ 20%	6kV
PFMA-7-UNV1	14.70 (6.67)	6,800	115 lm/W	59.1	120-277 VAC, 50/60 Hz; 125-250 VDC	0.50	0.90	≤ 20%	6kV
PFMA-3-UNV3	14.70 (6.67)	3,400	111 lm/W	30.3	347-480 VAC, 50/60 Hz	0.09	0.90	≤ 20%	6kV
PFMA-5-UNV3	14.70 (6.67)	5,200	116 lm/W	43.7	347-480 VAC, 50/60 Hz	0.13	0.90	≤ 20%	6kV
PFMA-7-UNV3	14.70 (6.67)	6,800	115 lm/W	56.2	347-480 VAC, 50/60 Hz	0.16	0.90	≤ 20%	6kV

Champ Pro PFMA LED floodlights

3,000 to 7,000 lumens

UL Listed
CSA Certified
Marine & Wet Locations
Type 4X; IP66

5L

Design features:

Our Champ LED floodlight is a field-proven design that helps ensure safety, reliability and performance in harsh and heavy industrial areas. The new form factor is engineered to deliver more operational value and better total cost of ownership.

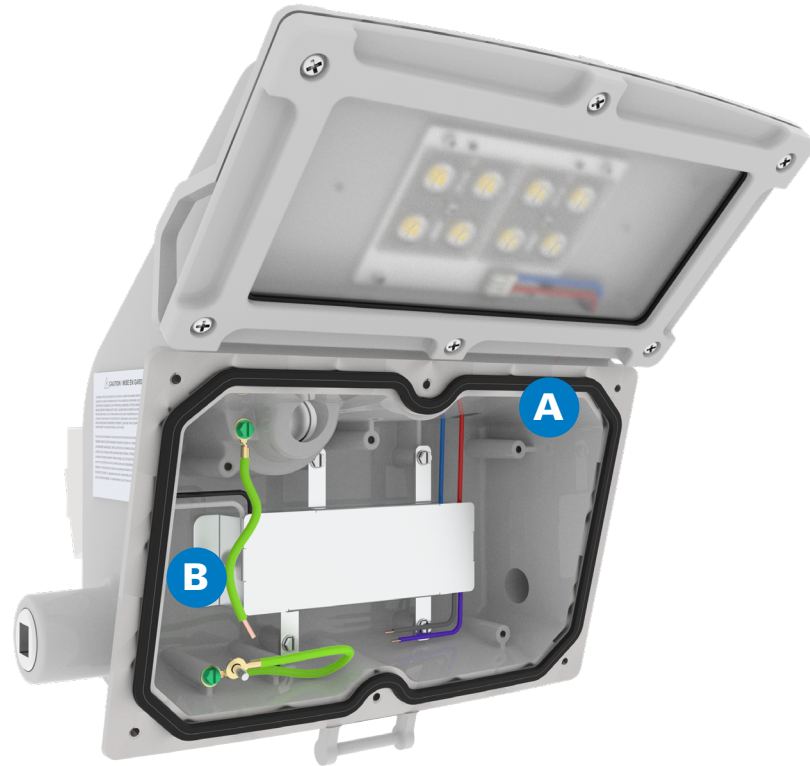

INSTALLATION EASE

A Easy access

- Removable covers for LED engine and driver compartments enable faster installation, access to wiring and field maintenance

B Lever lock connectors and terminal blocks

- Plug and play wiring simplifies and speeds installations

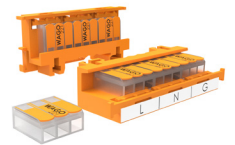

C Versatile mounting options

- Standard yoke mount and optional wall and hub mounts help ensure that the fixtures are installed in the correct location to properly light your facility

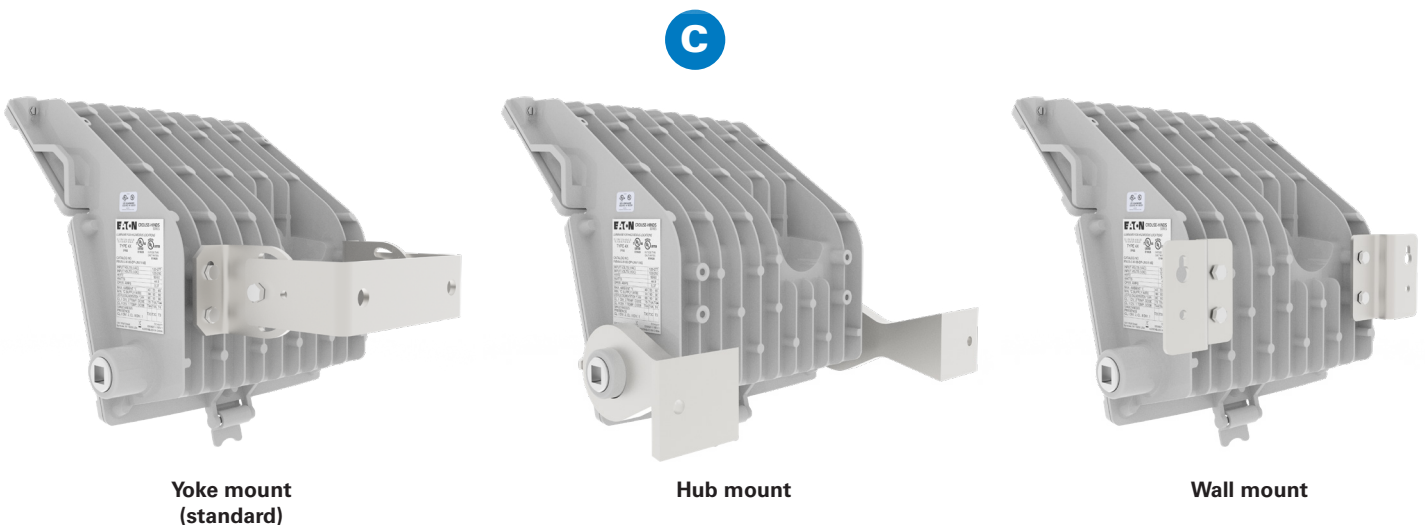

Yoke mount
(standard)

Hub mount

Wall mount

Champ Pro PFMA LED floodlights

3,000 to 7,000 lumens

UL Listed
CSA Certified
Marine & Wet Locations
Type 4X; IP66

5L

LONG-LIFE RELIABILITY

D Thermal management

- Heat fins help ensure proper air flow and facilitate dust shedding for effective heat dissipation and thermal management of LED engine

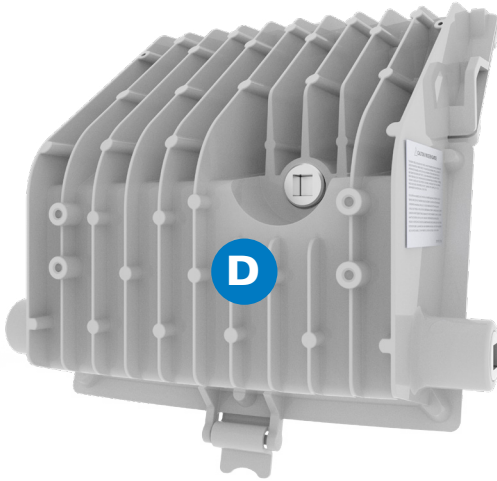

E Performance in extreme environments

- Operating ambient: -40°C to 65°C
- Type 4X, IP66
- 6kV surge protection
- Corrosion-resistant aluminum housing with Corro-free epoxy powder coating
- Vibration tested in accordance with Section 33 of UL844
- Impact tested in accordance with Section 68 of UL844



LIGHT PERFORMANCE & QUALITY

F Custom optics & colors

- Directs light where you need it, helping eliminate gaps and dark spots
- Can potentially reduce the number of light fixtures required in your application
- 3000K (warm), 4000K (neutral) and 5000K (cool) color options available

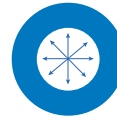

NEMA 6x6

Large circular distribution pattern for indoor and outdoor area lighting



5000K – cool

Crisp, bright white with a blue hue



3000K – warm

Warm white with a yellow hue

5L

Champ Pro PFMA LED floodlights

3,000 to 7,000 lumens

UL Listed
CSA Certified
Marine & Wet Locations
Type 4X; IP66

5L

Ordering information:

Part number example

PFMA-3-W-T-66-DP-GV-UNV1-PC2-M2

PFMA - 3 - W - T - 66 - DP - GV - UNV1 - - PC2 - M2

Light source / intensity

3L	3,400 nominal lumens
5L	5,200 nominal lumens
7L	6,800 nominal lumens

Color temperature

BLANK	5000K, 70 CRI (cool white)
N^A	4000K, 70 CRI (neutral white)
W	3000K, 80 CRI (warm white)

Mounting

BLANK	Yoke mount
H	Hub mount
T	Wall mount

Optics

66	6x6 beam spread
-----------	-----------------

Lens material

BLANK	Clear glass
DG	Diffused glass
PC	Polycarbonate
DP	Diffused polycarbonate

Guard and visor

BLANK	None
G	Bolt-on wire guard
V	Visor
GV	Bolt-on wire guard & visor

Voltage

UNV1	120-277 VAC, 50/60 Hz; 125-250 VDC
UNV3	347-480 VAC, 50/60 Hz

Paint

BLANK	Gray
--------------	------

Sensor

BLANK	No sensor included
PC1^B	120V photocell
PC2^B	208-277V photocell

Accessories (ordered separately):

Description

Description	Cat. #
• Visor.....	DSV4
• Bolt-on wire guard.....	P64
• Safety cable.....	SC831
• Floodlight slipfitter.....	SFA6
• Slipfitter wall mount adapter.....	SWB6

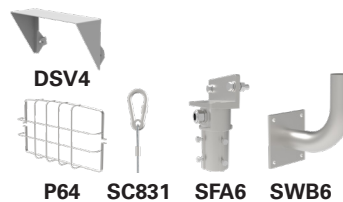

Replacement driver kits (ordered separately)

FMVA-3-5-7-UNV1-M2-DRIVER KIT	UNV1 M2 replacement driver kit for FVMA-3, -5 and -7
FMVA-3-5-7-UNV3-M2-DRIVER KIT	UNV3 M2 replacement driver kit for FVMA-3, -5 and -7
FMVA-3-5-7-UNV1-PC-M2-DRIVER KIT	For use in models with photocell; UNV1 M2 replacement driver kit for FVMA-3, -5 and -7

^AConsult customer service for lead time.

^BFor use with UNV1 models only.

Champ Pro PFMA LED floodlights

3,000 to 7,000 lumens

UL Listed
 CSA Certified
 Marine & Wet Locations
 Type 4X; IP66

5L

Dimensions – standard yoke mount:

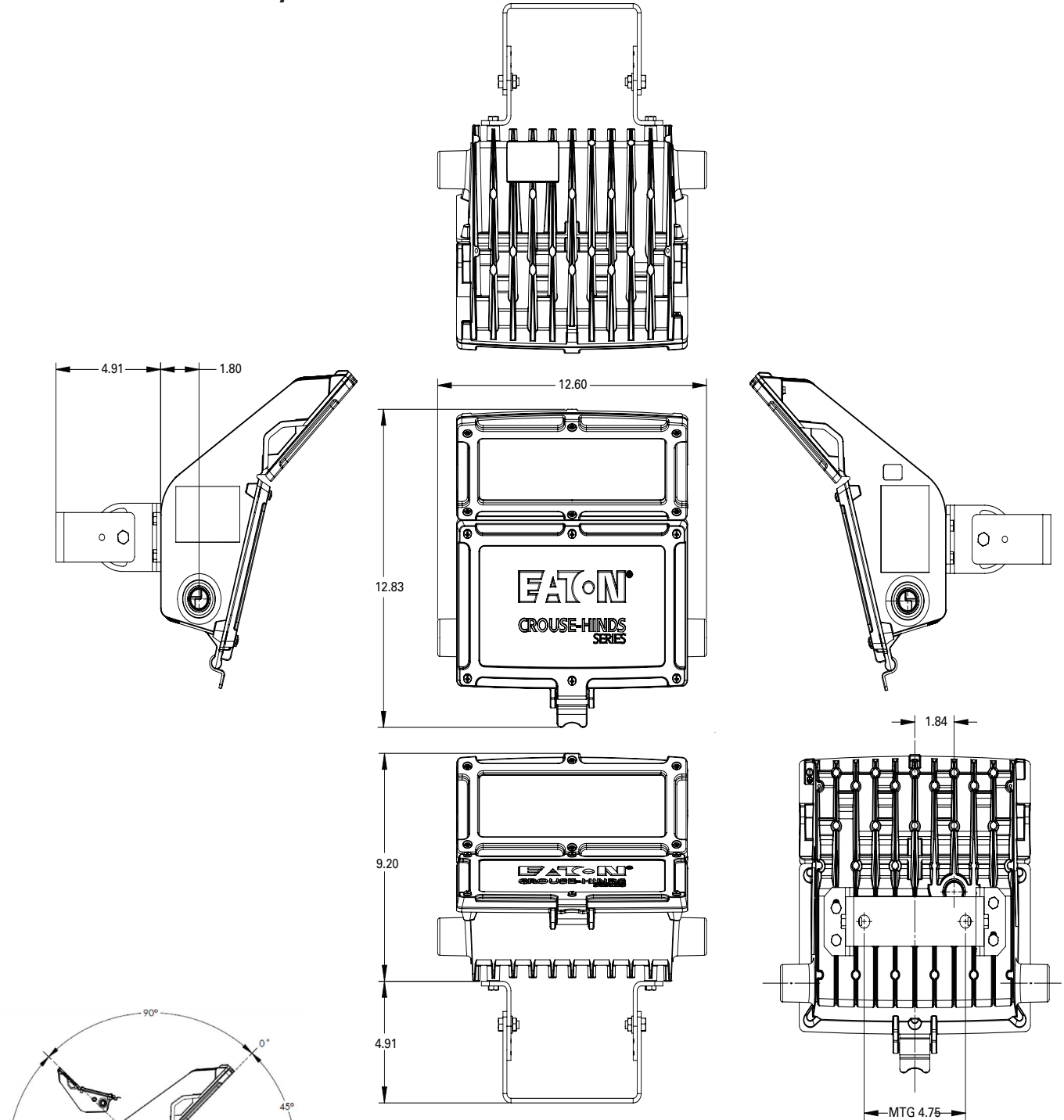

5L

Mounting method	Angle range	Mounting surface
Yoke (standard)	+45° to -90°	Wall, ceiling, horizontal surface/ground

Champ Pro PFMA LED floodlights

3,000 to 7,000 lumens

UL Listed
 CSA Certified
 Marine & Wet Locations
 Type 4X; IP66

5L

Dimensions – hub mount (optional):

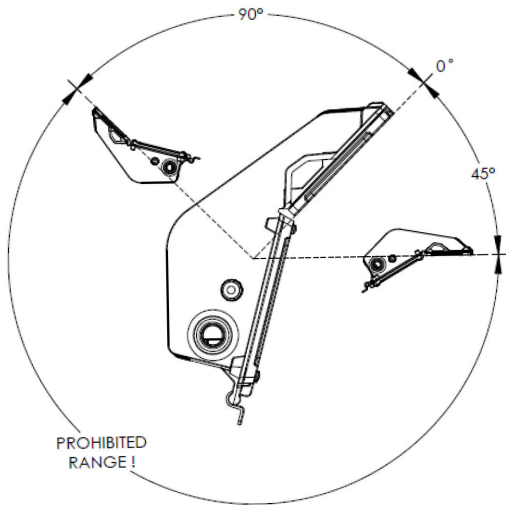
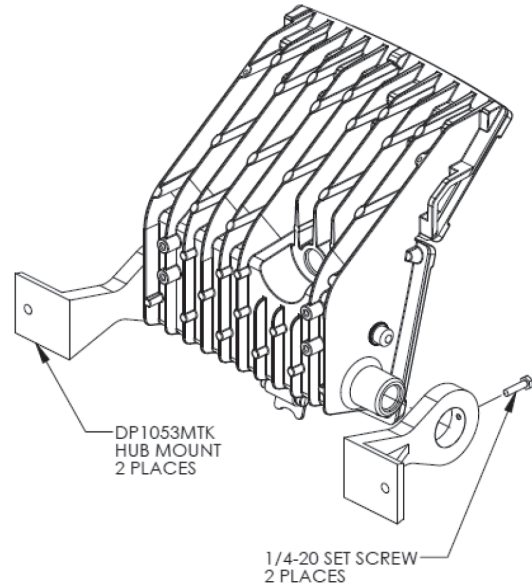
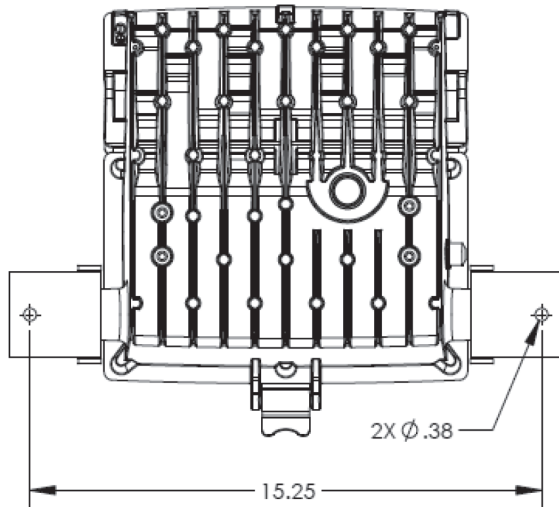

Mounting method	Angle range	Mounting surface
Hub	+45° to -90°	Wall, ceiling, horizontal surface/ground

5L

Champ Pro PFMA LED floodlights

3,000 to 7,000 lumens

UL Listed
CSA Certified
Marine & Wet Locations
Type 4X; IP66

5L

Dimensions – wall mount (optional):

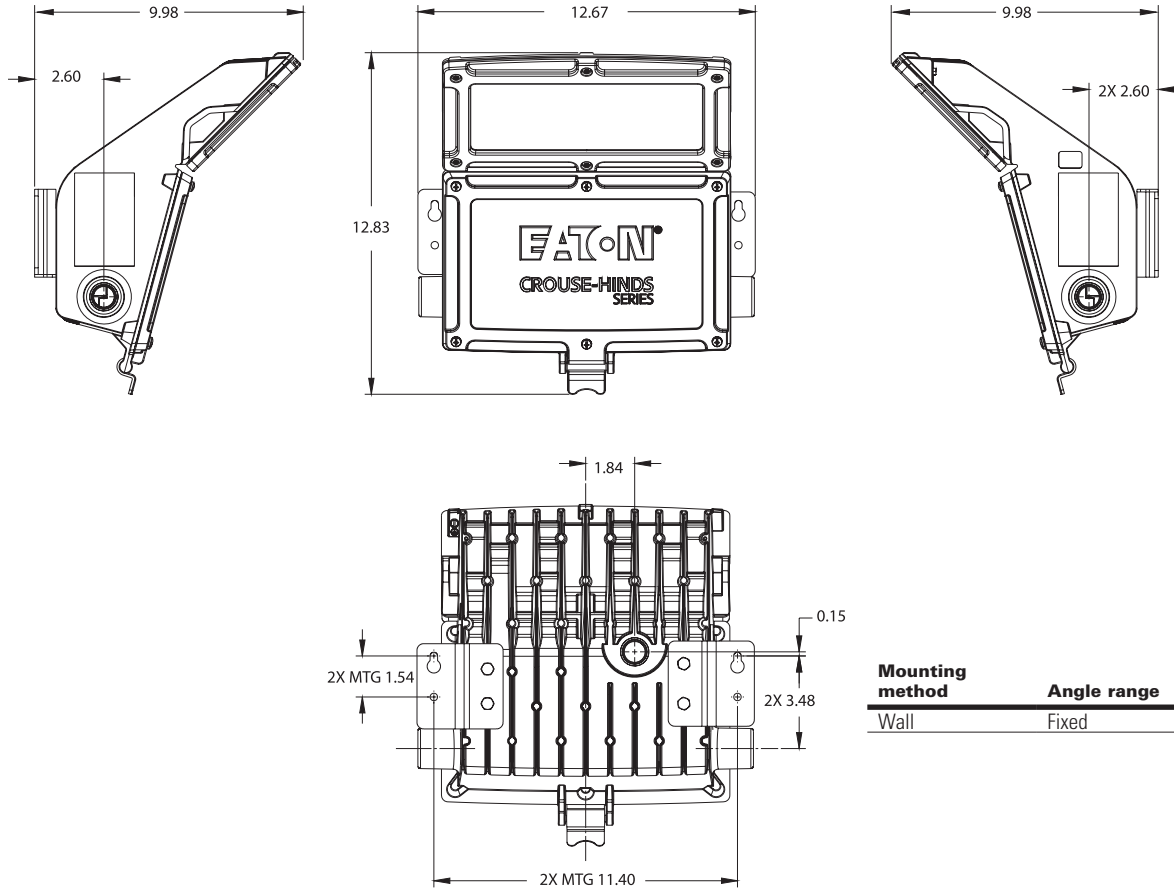

5L