

Heavy industrial LED lighting

CROUSE-HINDS  
SERIES

# Champ Pro PVML

## LED lighting for harsh & heavy industrial



**Safe. Reliable. Efficient.**  
3,000 to 13,000 lumens

**EATON**

*Powering Business Worldwide*



## Champ PVML LED

# Safe. Reliable. Efficient.

Featuring a broad range of LED luminaires for harsh, hazardous and industrial environments, Eaton Crouse-Hinds series lighting solutions are designed to perform reliably in the most extreme conditions while helping reduce energy, maintenance and manpower costs.

### Why LED?

#### **Useful life**

Rated life is up to 60,000 hours of maintenance-free and safe operation

#### **Energy efficiency**

LED average energy consumption is significantly less than traditional fluorescent and HID fixtures

#### **Start/restart time**

Instant illumination versus 10 minute restrike time for HID

#### **Light quality**

Higher color rendering compared to fluorescent and HID

#### **Environmental benefits**

Mercury-free LED eliminates disposal costs and has lower energy consumption

### Why Crouse-Hinds?

#### **Rugged design**

Built to withstand extreme temperatures, vibration, water and dust

#### **High efficacy**

Up to 127 lumens per watt (model dependent)

#### **Thermal management**

Effective heat sinking ensures longer life

#### **Quality of light**

Custom optics designed to maximize light distribution and intensity

#### **Versatile mounting**

LED fixtures are compatible with Crouse-Hinds series HID installed base

# Design features

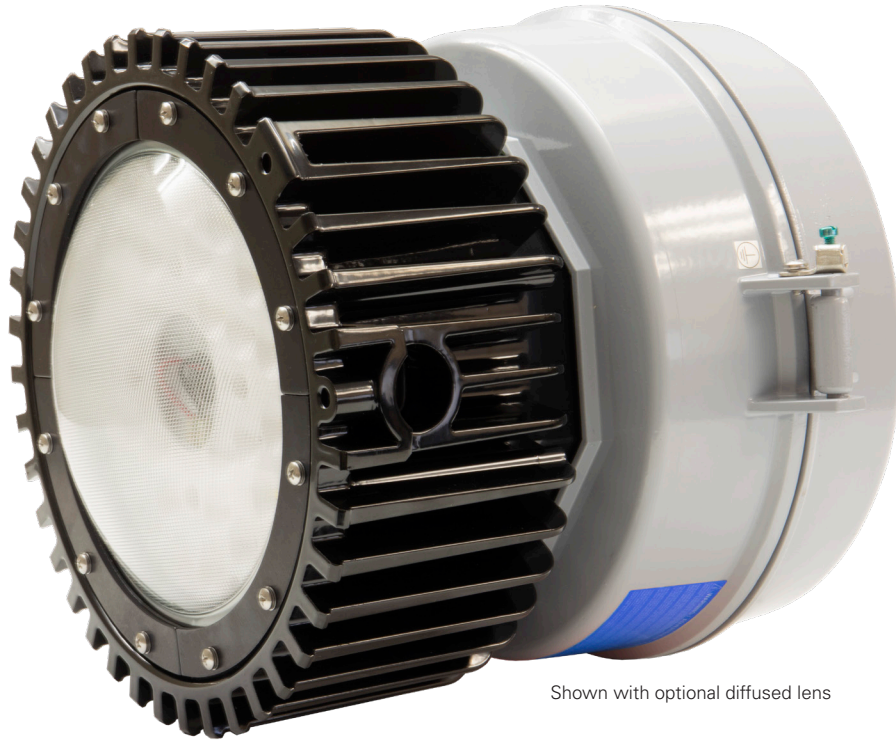

Shown with optional diffused lens

### Built to last:

- Type 4X and IP66 rated
- Impact-resistant lens sealed from the outside environment provides ingress protection against water and dust
- Die cast aluminum LED housing provides efficient thermal path to heat sink assembly
- Vertical fin design facilitates air flow and dust shedding

### Simple installation and replacement:

- Contractor-friendly design is ideal for both retrofit and new construction
- Easy to retrofit using existing HID Champ mounting module
- Straightforward wiring with lever lock connectors

### Custom optics:

- Type I, III and V optics designed to maximize light distribution and intensity\*
- \* Type V optics standard.

### Increased efficiency:

- Up to 127 lumens per watt (7L model)



Shown with optional uplight refractor lens and guard

### Multiple lens options:

- Clear glass lens standard
- Uplight refractor lens provides ~5% uplight and ~16% sidelight for better visibility
- Optional lenses include diffused glass, clear polycarbonate or uplight refractor



ORDC/UNV1

REMOTE CONTROL 1

Occupancy sensor and remote (ordered separately)

### Occupancy sensor:

- Optional occupancy sensor with photocell available
- Remote control for customizing occupancy sensor performance

## Why choose Champ PVML?

**Safe, reliable and efficient.** PVML LED luminaires are engineered to deliver high lumen output and maintenance-free long life in the toughest conditions.

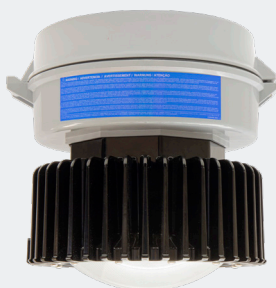

### PMVL-7 vs. 175 watt HID



**77%**  
ENERGY  
EFFICIENCY



**75%**  
TOTAL COST  
OF OWNERSHIP



**100%**  
MAINTENANCE  
REDUCTION

Assumptions: Calculations based on overall life of the LED system. Energy cost of \$.09 per kilowatt; 24 hour per day operation; labor rate of \$75 each for 2 workers; average time for fixture maintenance of 1 hour.

# Custom optics

Eaton's Crouse-Hinds continuously focuses on engineering product solutions tailored to our customers' unique needs and applications.

Champ PVML LED luminaires feature custom optics designed to maximize light distribution and intensity, providing flexibility for retrofits or new installations throughout the site.



Type V optics distribute light where you need it

## Three optical options to maximize light distribution and intensity

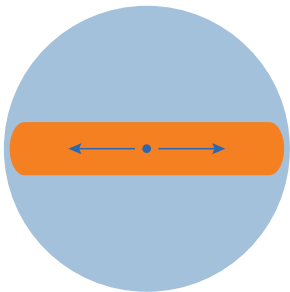

### TYPE I

Long and rectangular for hallways, walkways, loading docks, catwalks.

**Ideal for:**

- Mining conveyor belts
- Aisleways and hallways
- Catwalks and walkways
- Ramps and loading docks
- Tunnels with overhead mounts

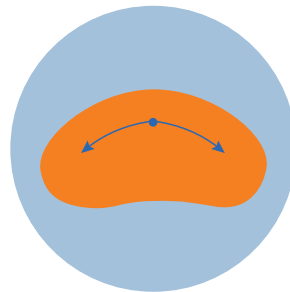

### TYPE III

Wall mount light distribution, minimizing spillover on the wall.

**Ideal for:**

- Narrow crosswalks or passages with wall mounted fixtures
- Tunnels with wall mount
- Wall or stanchion mount requiring 180° forward throw beam patterns

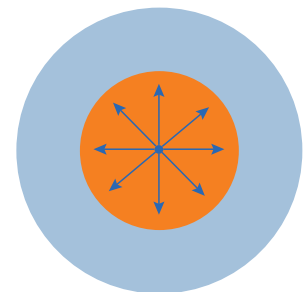

### TYPE V

Regular circular distribution pattern for high/low bay indoor and outdoor ceiling or pendant mount lighting.

**Ideal for:**

- Pendant, ceiling or stanchion mount overhead building mounts
- Processing mills, industrial plants, large buildings, warehouses, etc.

# Case study: Type I optics

## Catwalk/conveyor lighting

Utilizing Eaton’s Crouse-Hinds lighting layout services, Champ Pro PVML luminaires with Type I optics and HID luminaires are shown installed on a catwalk to compare photometrics.

Champ Pro PVML w/ Type I optics

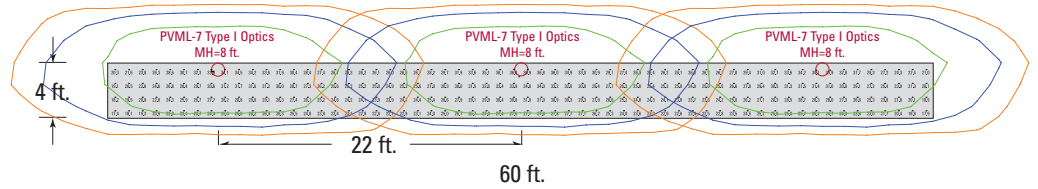

## Comparison

**Champ Pro Type I LEDs have a wider linear pattern** than equivalent HID luminaires and provide more efficient light dispersion, which fully illuminates the catwalk.

175W metal halide w/ Type I optics

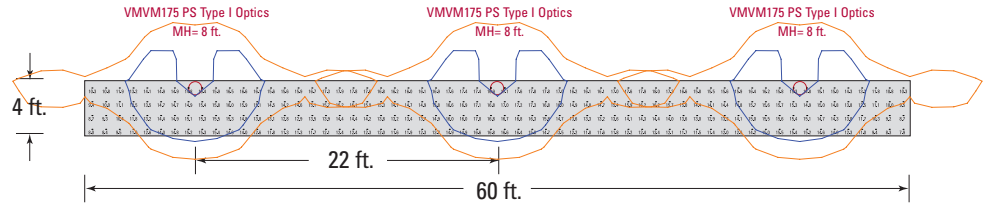

## Results

**Champ Pro PVML LED with Type I optics** provides superior illumination along the conveyor and walkway safely. With no gaps in illumination, the optical pattern allows for increased spacing of fixtures and a safer conveyor system.

Luminaire	Calc. type	Units	Avg.	Max.	Min.	Avg./min.	Max./min.
Champ Pro PVML	Illuminance	Fc	26.91	36.9	17.4	1.55	2.12
175W MH	Illuminance	Fc	14.32	18.0	7.9	1.81	2.28

## Savings realized

- **Champ Pro Type I pattern allows for greater fixture spacing** along the catwalk or conveyor system
- Increased visibility with no dark spots results in safer conditions for workers
- Up to 77% energy savings over the life of the fixture

**Champ Pro has broader coverage area, higher delivered footcandles and uniformity for a typical catwalk or conveyor application.**

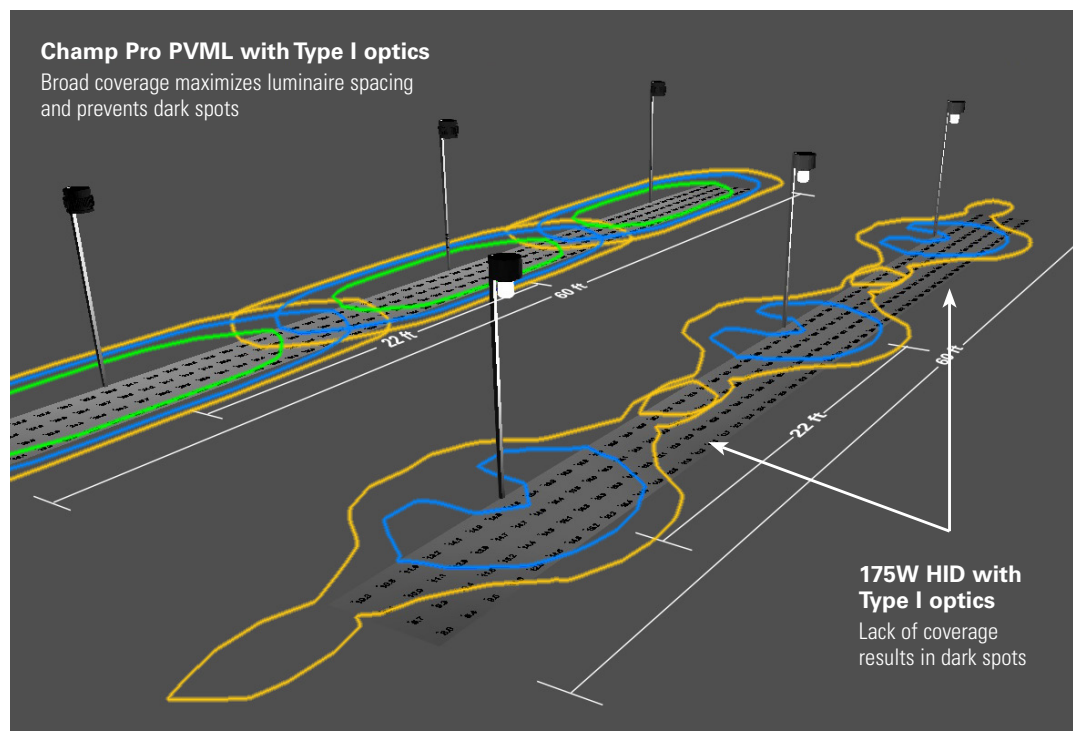

### Lighting layout & design services:

Let us help you design your next big project!

Contact Crouse-Hinds Customer Service  
 crousecustomerctr@eaton.com

(866) 764-5454

## Rugged solutions for complex environments.

Champ Pro PVML LED luminaires are engineered to provide maintenance-free illumination in the most demanding harsh and heavy industrial environments.

The Champ PVML features a compact, high efficacy design with custom optics to ensure maximum efficiency and mounting flexibility, including the ability to retrofit the Crouse-Hinds installed base to service both LED upgrades and new projects.

Model	Nominal lumens*	Watts	Efficacy	Equivalent HID
PVML-3	3,302	27	122 lm/W	70W
PVML-5	5,412	43	126 lm/W	100W
PVML-7	7,327	57	129 lm/W	175W
PVML-9	9,229	75	123 lm/W	250W
PVML-11	11,266	92	122 lm/W	320W
PVML-13	13,093	92	142 lm/W	400W

\*Nominal lumens based on Type V optics, 5000K CCT with clear glass lens. Wattage measured at 120 VAC.

### Applications:

- Non-hazardous locations with mounting heights up to 30 feet
- Heavy industrial, mine site processing areas, platforms, loading docks, tunnels, indoor/outdoor spotlighting, outdoor wall, stanchion mounted general area lighting and areas requiring frequent on-and-off of lights
- Locations requiring continuous and consistent light levels in extreme ambient temperatures
- Where extremely corrosive, wet, dusty, hot and/or cold conditions exist
- Type 4X, IP66, marine, wet locations and hose down environments

### Champ Pro PVML benefits:

- Instant illumination and restrike
- Dimmable driver, 0-10V
- Better visibility with crisp, white light
- Cold temperature operation / no warm-up required
- Option for redundant drivers to avoid complete loss of illumination
- Easy installation - compact modular fixture attaches onto existing Champ mounting module
- Energy-efficient - up to 77% energy savings over HID
- Contains no mercury or other hazardous substances
- Shock- and vibration-resistant solid-state luminaires have no filaments or glass components that could break - greatly reduces the risk of premature failure
- Operating ambient: -40°C to +65°C
- Full cut-off with no wasted light above the fixture
- 5 year fixture warranty†

†Refer to the current distributor price book for Crouse-Hinds standard Terms and Conditions.

## Uplight refractor lens now available



## Maximize light dispersion

The new uplight refractor lens is perfect for low bay ceilings, suspended pendant mounts, areas with elevated infrastructure or areas which require dispersed side and uplight illumination.

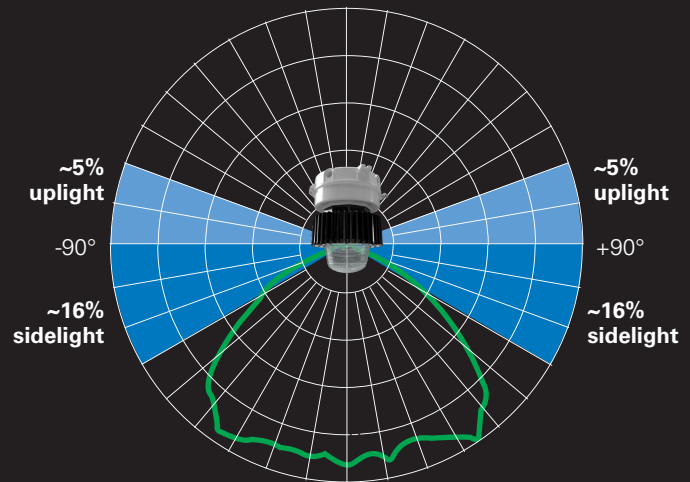

## More directional light ~5% uplight and ~16% sidelight for better visibility



For more information go to:

[Crouse-Hinds.com/ChampLED](http://Crouse-Hinds.com/ChampLED)

**Certifications and compliances:**

- DesignLights Consortium® Qualified (pending)\*

**NEC and CEC**

- Wet Locations, Type 4X, IP66

**UL Standards**

- UL1598 Luminaires, UL1598A Marine

**CSA Standard**

- cUL Listed to CSA Standard CSA C22.2 No. 250

**IEC Standard**

- CE

\*Refer to www.designlights.org Qualified Products List under family models for full listing details. Not all models are approved for all application categories.

**Colored LED options:**

- Available in green or amber\*
- Reduction in light pollution for night space observation and sky glow due to isolating blue wavelength in red and amber colors
- Wildlife-friendly
- Improves visibility for telescopes in observatories during night sky space exploration

\*Custom optics not available with colored LEDs. One model per color, see assignment sheet.

**Enhanced Surge Protection:**

- Standard: 6kV IEC rated (6 kV/3kA L-L, 10 kV/0.83kA L-G)
- SG1 option: 6kV IEC & ANSI rated (6kV/3kA L-L & L-G)

**Standard materials:**

- Lamp housing and adapter - die cast aluminum with Corro-free™ epoxy powder coat
- Lens - heat- and impact-resistant glass
- Gaskets - silicone
- External hardware - stainless steel
- Factory-sealed, no external seals required

**Accessories (ordered separately):**

- Photocell, 120V, 50/60 Hz
- Photocell, 208-277V
- Occupancy sensor with photocell, 120/277 VAC
- Trunnion mount kit with redundant pin locking mechanism (ceiling mount required)
- Remote control for customizing occupancy sensor performance



ORDC/UNV1



REMOTE CONTROL 1

Occupancy sensor and remote (ordered separately)

**Electrical ratings:**

UNV1 driver	Input power (watts)	Input amps at 100-277 VAC	UNV34 driver	Input power (watts)	Input amps at 347-480 VAC
PVML-3	27	0.27-0.10	PVML-3	28	0.08-0.06
PVML-5	45	0.45-0.16	PVML-5	44	0.13-0.09
PVML-7	61	0.61-0.21	PVML-7	57	0.16-0.12
PVML-7-S892	60	0.60-0.23	PVML-7-S892	61	0.18-0.13
PVML-9	76	0.76-0.26	PVML-9	68	0.20-0.14
PVML-9-S892	80	0.80-0.29	PVML-9-S892	73	0.22-0.15
PVML-11	92	0.92-0.32	PVML-11	83	0.24-0.17
PVML-11-S892	97	0.97-0.35	PVML-11-S892	86	0.25-0.18
PVML-13	95	1.06-0.42	PVML-13	91	0.29-0.17
PVML-13-S892	95	1.10-0.36	PVML-13-S892	96	0.31-0.19

All models	
Power factor	≥0.90
THD	≤15%

UNV1		UNV34	
Voltage range, VAC*	100-277V at 50/60 Hz	Voltage range, VAC*	347-480V at 50/60 Hz
Voltage range, VDC	127-250V		

\*IEC voltage: 100-240 VAC @ 50/60 Hz.  
\*\*For VMVL3: PF>0.9 from 100-255 VAC.

EMC / CE compliance:  
If the dimming interface of the LED driver is connected to an external dimmer which is not provided with the luminaire, a ferrite core must be used on the input and dimming lines. Approved ferrite cores are: Fair-Rite P/N 0431167281.

**Options:**

- Wire guard with captive mounting hardware
- Trunnion mount with pin locking (ceiling mount required)
- Quick Clip for quick installation
- Diffused lens for glare reduction
- Redundant driver for prevention of total loss of illumination
- Polycarbonate lens for areas where glass is prohibited
- Six-pole terminal block

**LED system:**

- High intensity discrete LEDs
- Standard: cool white (5000K, 70 CRI); optional: warm white, (3000K, 80 CRI) or neutral white (4000K, 70 CRI†)
- Custom Type I, III and V optics available

†Only available for 9L - 13L models.

**Weights:**

Model	lbs.	kg.	Mounting module	lbs.	kg.
PVML-3 to PVML-7	19.00	8.62	Pendant	1.25	0.57
PVML-9 to PVML-13	19.20	8.70	Cone pendant	4.00	1.81
			Flexible pendant	1.50	0.68
			Ceiling	2.75	1.25
			Wall	4.50	2.04
			Angled stanchion	3.50	1.59
			Straight stanchion	4.50	2.04

# Ordering information

Part number example: **PVML-3-W-2A-G-UNV1-S831-UPLT**

Champ PVML, 3,000 lumens, 3000K warm white, ¾" pendant mount, Type V optics, wire guard, 100-277 VAC driver, safety cable, upright refractor lens

## PVML - 3 - W - 2A - G - UNV1 - S831 - UPLT

### Light source/intensity

<b>3</b>	3,250 nominal lumens
<b>5</b>	5,537 nominal lumens
<b>7</b>	7,442 nominal lumens
<b>9</b>	9,234 nominal lumens
<b>11</b>	11,114 nominal lumens
<b>13*</b>	13,100 nominal lumens
<b>A</b>	Amber - 5,200 lumens
<b>G</b>	Green - 4,300 lumens

\*For 13L models, add "-M2" suffix at the end of the part number.  
Example: PVML-13-2A-R1-UNV1-S831-M2

### Color temperature

<b>BLANK</b>	5000K, 70 CRI (cool white)
<b>N*</b>	4000K, 70 CRI (neutral white)
<b>W</b>	3000K, 80 CRI (warm white)

\*Consult factory for lead time. Only available for 9L - 13L models.

\*\*5700K and 6500K are available upon request; consult factory.

\*\*\*Not available for Amber or Green LED.

### Mounting

<b>BLANK</b>	No mounting module
<b>J</b>	1-½" stanchion, 25° angled
<b>P</b>	1-½" stanchion, straight
<b>2A</b>	¾" pendant
<b>3A</b>	1" pendant
<b>20A</b>	20mm pendant

<b>25A</b>	25mm pendant
<b>2B</b>	¾" cone pendant
<b>3B</b>	1" cone pendant
<b>2HA</b>	¾" flexible pendant
<b>2C</b>	¾" ceiling
<b>3C</b>	1" ceiling

<b>20C</b>	20mm ceiling
<b>25C</b>	25mm ceiling
<b>2TW</b>	¾" wall
<b>3TW</b>	1" wall
<b>20TW</b>	20mm wall
<b>25TW</b>	25mm wall

### Lens guard

<b>BLANK</b>	No guard
<b>G</b>	Wire guard

### Optics

<b>BLANK</b>	Type V optic standard
<b>R1</b>	Type I optic (all mounts minus ceiling)
<b>R1A*</b>	Type I optic (ceiling with conduit 45° counterclockwise from top hat hinge)
<b>R1B*</b>	Type I optic (ceiling with conduit 135° clockwise from top hat hinge)
<b>R3</b>	Type III optic (all mounts minus ceiling)
<b>R3AP*</b>	Type III optic (select when using Appleton® top hat adapter with Champ fixture)
<b>R3A1*</b>	Type III optic (ceiling with conduit 45° counterclockwise from top hat hinge)
<b>R3A2*</b>	Type III optic (ceiling with conduit 135° clockwise from top hat hinge)
<b>R3B1*</b>	Type III optic (ceiling with conduit 45° clockwise from top hat hinge)
<b>R3B2*</b>	Type III optic (ceiling with conduit 135° counterclockwise from top hat hinge)

\*Available with ceiling mount modules only.

### Accessories & options†

<b>S812</b>	Trunnion mount kit with pin (available with ceiling mount only)
<b>S831</b>	Safety cable
<b>S890</b>	Quick clip
<b>S892*</b>	Redundant driver
<b>SG1***</b>	Enhanced ANSI compliant surge rating
<b>TB6**</b>	Six-pole terminal block

†Ordered with fixture or available separately.

\*Available for PVML-7, 9, 11 and 13 only

\*\*For NEC/CEC only.

\*\*\*Not available on 11L, 13L and all UNV34 models.

### Voltage‡

<b>UNV1</b>	100-277 VAC, 50/60 Hz; 127-250 VDC
<b>UNV34</b>	347-480 VAC, 50/60 Hz

‡IEC voltage; 100-240 VAC at 50/60 Hz.

### Lens material

<b>BLANK</b>	Clear glass
<b>S891</b>	Diffused glass
<b>S903</b>	Polycarbonate
<b>UPLT**</b>	Uplight refractor lens

\*\*For use with Type V optic only.

## Accessories (ordered separately)

### Replacement driver kits

<b>VMVL-3-5-7L-UNV1-DRIVER-KIT</b>	UNV1 replacement driver kit for VMVL-3, -5 and -7
<b>VMVL-9-11L-UNV1-DRIVER-KIT</b>	UNV1 replacement driver kit for VMVL-9 and -11
<b>VMVL-96W-13L-UNV1-M2-DRIVER-REPL-KIT</b>	UNV1 replacement driver kit for VMVL-13
<b>VMVL-3L-5L-UNV34-DRIVER-KIT</b>	UNV34 replacement driver kit for VMVL-3 and -5
<b>VMVL-7L-UNV34-DRIVER-KIT</b>	UNV34 replacement driver kit for VMVL-7
<b>VMVL-9L-UNV34-DRIVER-KIT</b>	UNV34 replacement driver kit for VMVL-9
<b>VMVL-11L-UNV34-DRIVER-KIT</b>	UNV34 replacement driver kit for VMVL-11
<b>VMVL-13-M2-DRIVER-KIT</b>	UNV34 replacement driver kit for VMVL-13
<b>VMVL-7L-S892-UNV1-DRIVER-KIT</b>	UNV1 replacement redundant driver kit for VMVL-7
<b>VMVL-9L-11L-S892-UNV1-DRIVER-KIT</b>	UNV1 replacement redundant driver kit for VMVL-9 and 11
<b>VMVL-13-UNV1-S892-M2-DRIVER-KIT</b>	UNV1 replacement redundant driver kit for VMVL-13
<b>VMVL-7L-S892-UNV34-DRIVER-KIT</b>	UNV34 replacement redundant driver kit for VMVL-7
<b>VMVL-9L-S892-UNV34-DRIVER-KIT</b>	UNV34 replacement redundant driver kit for VMVL-9
<b>VMVL-11L-S892-UNV34-DRIVER-KIT</b>	UNV34 replacement redundant driver kit for VMVL-11
<b>VMVL-13-UNV34-S892-M2-DRIVER-KIT</b>	UNV34 replacement redundant driver kit for VMVL-13
<b>VMVL-AL-GL-UNV1-DRIVER-KIT</b>	UNV1 replacement driver kit for amber or green models

### Mounting & hardware

<b>VMVL S812 K1</b>	Trunnion mount kit with pin*
<b>VMVL S812 K1 DBR</b>	PVC coated trunnion mount kit with pin*
<b>VMVL S831 K1</b>	Safety cable
<b>VMVL S890 K1</b>	Quick Clip

\*Available with ceiling mounted modules only.

### Mounting adapters

<b>CHMM1</b>	Mounting adapter for Appleton MercMaster III mounts
<b>CHMM2</b>	Mounting adapter for Appleton MercMaster II mounts
<b>CHMM3</b>	Mounting adapter for Thomas & Betts HazLux mounts
<b>CHMM4</b>	Mounting adapter for GE H2 Filtr-Gard mounts

### Photocells

<b>D2S20</b>	Photocell, 120V
<b>D2S208 277</b>	Photocell, 208-277V

### Lens guard

<b>PA3001</b>	Wire guard
<b>P3003</b>	UPLT wire guard

# Occupancy sensor

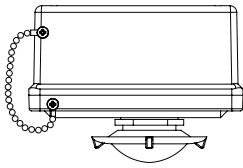

## Occupancy sensors

**ORDC/UNV1** 3/4" NPT entry, 100-277 VAC

## Occupancy sensor accessories (ordered separately)

<b>CABLE KIT ORD 1</b>	TECK armored cable (5 ft) with TECK glands (3/4")
<b>CABLE KIT ORD 2</b>	P Type non armored cable (5 ft) with ADE1F glands (3/4")
<b>CABLE KIT ORD 3</b>	Metal-clad armored cable (5 ft) with TMC glands (3/4")
<b>CABLE KIT ORD 4</b>	SO cable (5 ft) with ADE1F glands (3/4")
<b>ORDC WKIT</b>	Wall mount kit
<b>ORDC PKIT</b>	Pendant mount kit
<b>ORDC SKIT</b>	Stanchion mount kit
<b>REMOTE CONTROL 1</b>	Remote control for programming sensor

# Optics options

## R1, R3 and BLANK

Type I, III and V optics with all mounts minus ceiling

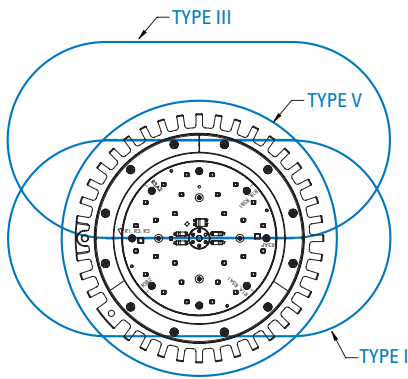

## R1A and R3A1

Type I and Type III ceiling mount only

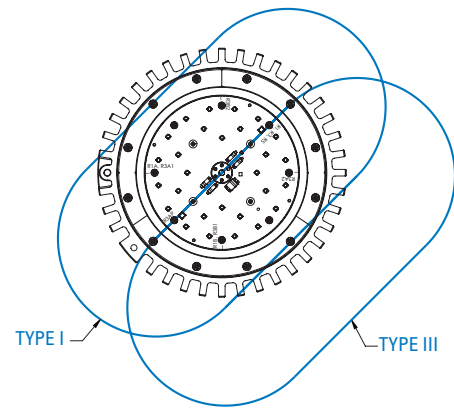

## R1B and R3B1

Type I and Type III ceiling mount only

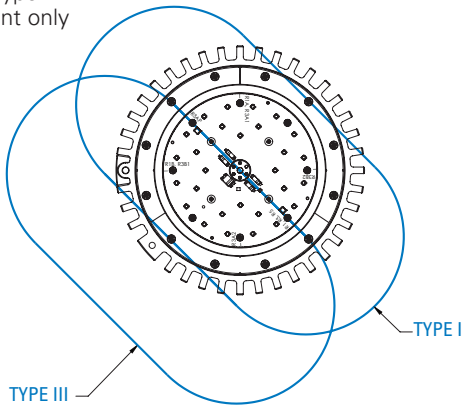

## R3AP

Type III wall mount

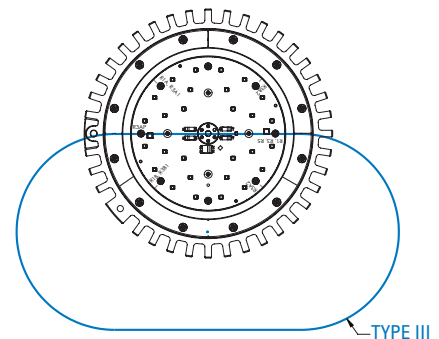

## R3A2

Type III ceiling mount only

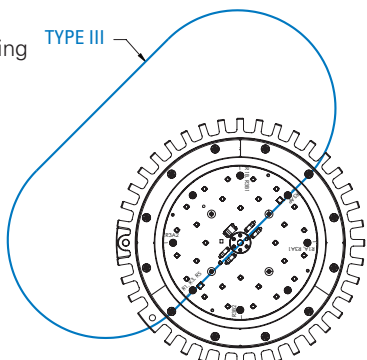

## R3B2

Type III ceiling mount only

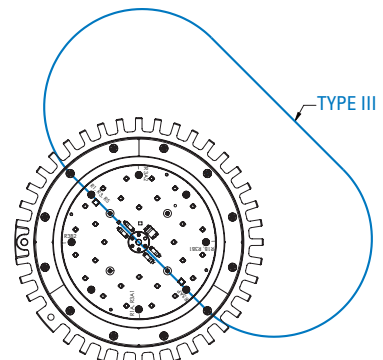

# Mounting options and dimensions:

## Stanchion - 25° angled

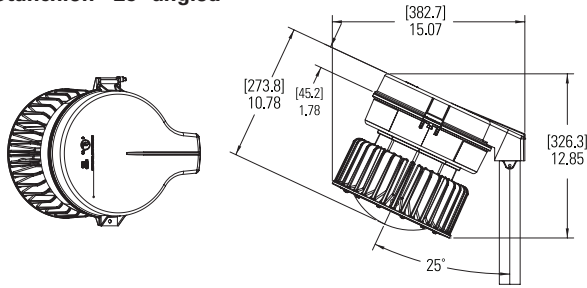

## Stanchion - straight

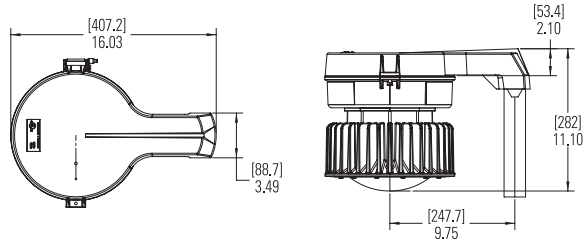

## Pendant

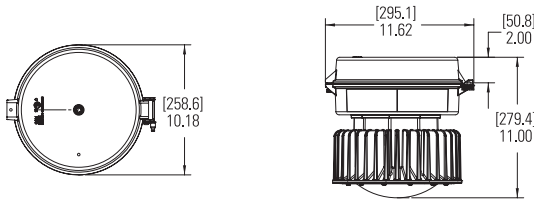

## Ceiling

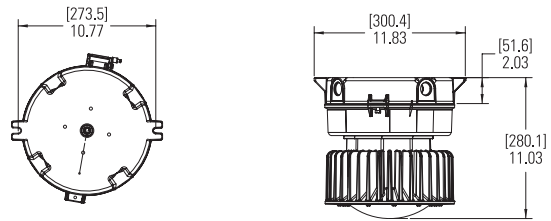

## Wall

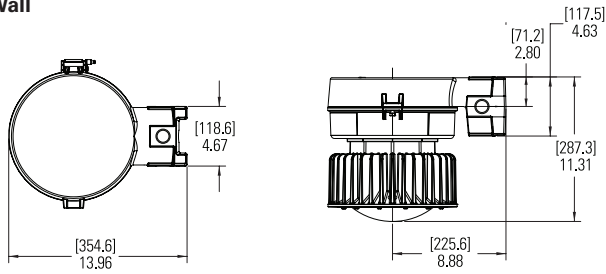

## Cone pendant

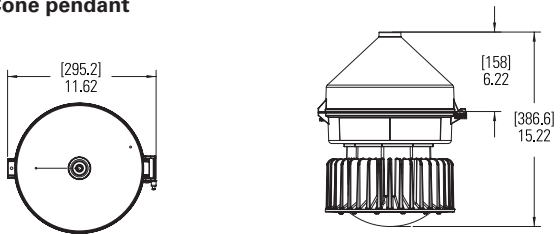

## Trunnion

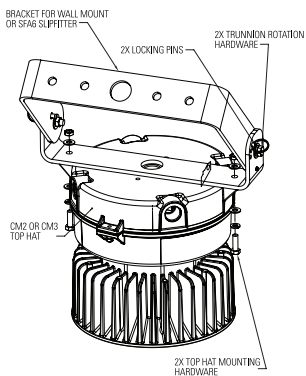

## Mounting module series

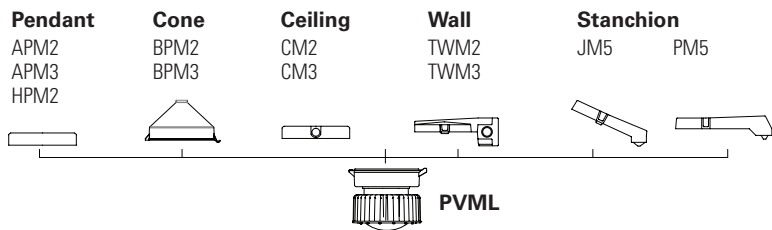

# Photometric comparison at 15 ft. mounting height

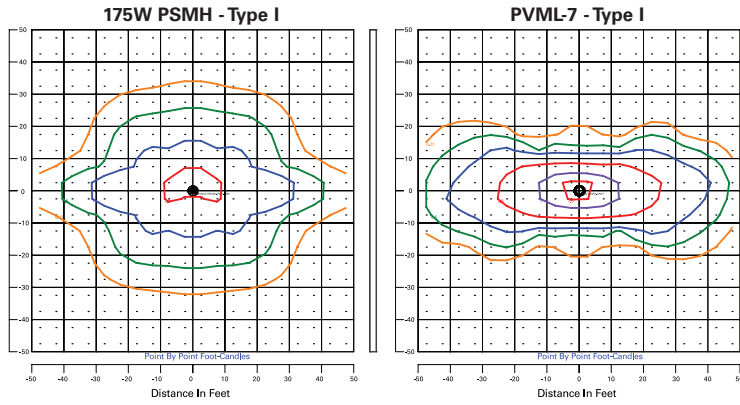

## Type I optical pattern



### Calculation summary

Label	Calc. type (in Fc)	Avg.	Max.	Min.
VMV 175W MH grid	Illuminance	0.49	3.0	0.0
PVML LED grid	Illuminance	0.56	7.1	0.0

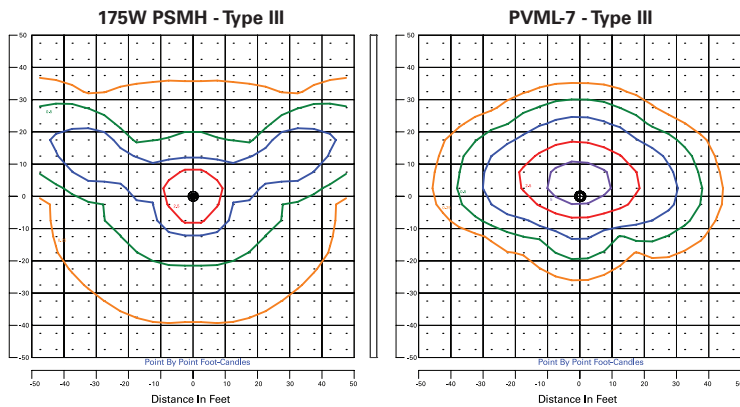

## Type III optical pattern



### Calculation summary

Label	Calc. type (in Fc)	Avg.	Max.	Min.
VMV 175W MH grid	Illuminance	0.59	4.5	0.1
PVML LED grid	Illuminance	0.54	6.8	0.0

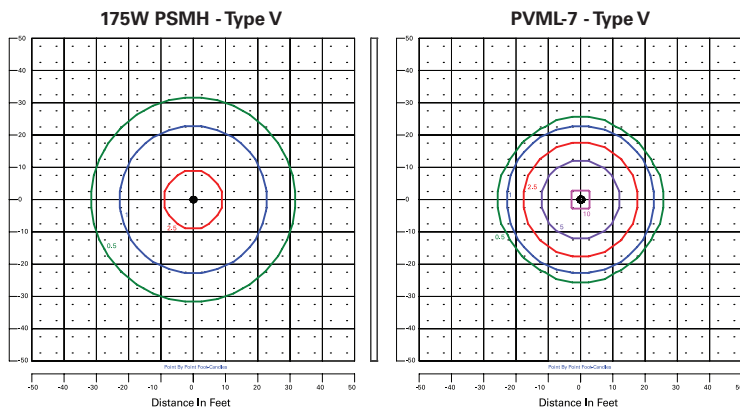

## Type V optical pattern



### Calculation summary

Label	Calc. type (in Fc)	Avg.	Max.	Min.
VMV 175W MH grid	Illuminance	0.51	2.8	0.1
PVML LED grid	Illuminance	0.60	9.1	0.0

Higher average footcandles, uniformity and distribution coverage with less than half the lumens and energy consumption compared to 175W metal halide

Actual lumens (nominal†)	PVML-3	PVML-5	PVML-7	PVML-9	PVML-11
Type I	3,360	5,045	6,844	8,823	10,730
Type III	3,309	4,468	6,741	8,618	10,660
Type V	3,250	5,537	7,442	9,234	11,114

†Tolerance +/- 10%.

**U.S. (global headquarters):  
Eaton's Crouse-Hinds business**

1201 Wolf Street  
Syracuse, NY 13208

(866) 764-5454  
FAX: (315) 477-5179  
FAX Orders Only:  
(866) 653-0640

[crousecustomerctr@eaton.com](mailto:crousecustomerctr@eaton.com)

**Eaton's B-Line business**

509 West Monroe Street  
Highland, IL 62249

800-851-7415  
FAX: 618-654-1917  
[Eaton.com/b-lineseries](http://Eaton.com/b-lineseries)

**IEC Electrical**

(CEAG products)  
49 (0) 6271 806-500  
FAX: 49 (0) 6271 806-476  
[Info-ex@eaton.com](mailto:Info-ex@eaton.com)

**Airport Lighting**

866-764-5454  
[CrouseCustomerCTR@Eaton.com](mailto:CrouseCustomerCTR@Eaton.com)

**Mexico/Latin America/Caribbean**

52-555-804-4000  
FAX: 52-555-804-4020  
[ventascentromex@eaton.com](mailto:ventascentromex@eaton.com)

**Haz Area Communications**

(MEDC, Hernis, Oxalis, FHF Sonix)  
44 (0) 1623 444400  
FAX: 44 (0) 1623 444531  
[MEDCadmin@Eaton.com](mailto:MEDCadmin@Eaton.com)

**Canada**

Toll Free: 800-265-0502  
FAX: (800) 263-9504  
FAX Orders only: (866) 653-0645

**China**

86-21-2899-3600  
FAX: 86-21-2899-4055  
[echsales@eaton.com](mailto:echsales@eaton.com)

**Process instrumentation**

(MTL products)  
44 (0) 1582 723633  
FAX: 44 (0) 1582 422283  
[enquiry@mtl-inst.com](mailto:enquiry@mtl-inst.com)

**Eaton Middle East**

9714-8066100  
FAX: 9714-8894813  
[CHBL-ME@eaton.com](mailto:CHBL-ME@eaton.com)

**Australia**

61-2-8787-2777  
FAX: 61-2-9609-2342  
[crousehindsanz@eaton.com](mailto:crousehindsanz@eaton.com)

**For more information:**

If further assistance is required, please contact an authorized Eaton Distributor, Sales Office, or Customer Service Department.

**Eaton**  
1000 Eaton Boulevard  
Cleveland, OH 44122  
United States  
[Eaton.com](http://Eaton.com)

© 2026 Eaton  
All Rights Reserved  
Printed in USA  
Publication No. BR403037EN  
February 2026

Eaton is a registered trademark.  
All other trademarks are property  
of their respective owners.

Follow us on social media to get the  
latest product and support information.

